

MINIM BASED GAMMA RAY SPECTROMETER



TYPE : GR611M

NUCLEONIX SYSTEMS PRIVATE LIMITED

Plot No: 162 A & B, Phase II, I.D.A. Cherlapally, Hyderabad - 500 051.

Phone: 040-29706483 / 84 / 85, Mobile No: 7331104481 / 82

E-mail: info@nucleonix.com Web : www.nucleonix.com

FILE_NAME : NSPL /DOC/ MAN / GR611M/01

VER_20170421

CONTENTS

S.No.	Description	
	Unpacking & Important note	
CHAPTER I	a. Introduction b. Front panel diagram c. Specifications d. Accessories & Lead Castle for scintillation detector	01-05
CHAPTER II	Front Panel & Rear Panel Controls	06-08
	Instructions on intelligent keypad commands	09-13
CHAPTER III	Default settings	14-14
CHAPTER IV	a. Block Diagram & Description	15-16
	b. System Interconnections	17-17
CHAPTER V	a. Operating Instructions	18-19
CHAPTER VI	Equipment Maintenance Services and Warranty Clause	20-23
CHAPTER VII	CONTACT US FOR AVAILING SERVICES	24-28

UNPACKING

Gamma Ray Spectrometer Type :GR 611M has been thoroughly tested and is despatched in ready to operate condition. However, on unpacking and prior to operation, it is advisable to check visually and make sure that there is no visible damage caused in transit.

If any damage to the instrument is observed, do not switch ON the unit and report the matter immediately to :

Customer Support Division
Nucleonix Systems Private Limited
Plot No : 162 A & B, PHASE II,
I.D.A.Cherlapally,
Hyderabad - 500 051.
e-mail : info@nucleonix.com

In all correspondence regarding the instrument, please mention the type, serial number of the unit, date of supply etc., of the unit.

Also if you find any short supply and missing items, not tallying with the packing slip, the same is to be reported immediately by e-mail/FAX and all the original packing is to be preserved intact till the matter is settled.

Important Note :

Before switching ON the system, please read CHAPTER - III default settings. After that make interconnection as per given details [CHAPTER- IV (b)], and switch ON the system. Place all the controls at the **default settings** for the system calibration initially. Once the system is calibrated for energy user may select the required MODE (INT/NOR/WIN) in SC530 module, bracket for the required energy band for the sample counting application.

CHAPTER - I

A. INTRODUCTION

GAMMA RAY SPECTROMETER TYPE : GR 611M manufactured by Nucleonix Systems is a state-of-art microcontroller based modular unit consisting of High Voltage Unit, Linear Amplifier, Single Channel Analyser and Counter timer (Microcontroller based) modules, housed in MINIM BIN & Power Supply MB 403.

The Gamma Ray Spectrometer GR 611M accepts the input from a Scintillation Detector in the form of electrical pulses proportional in amplitude to the incident Gamma energy. The High Voltage unit provides the necessary bias for scintillation detector. The detector output amplified by Linear Amplifier is fed to the Single Channel Analyser for pulse height analysis. The output events from SCA are counted for a preset time in Counter Timer unit. SCA is an important unit in GRS which scans the entire Gamma Spectrum. Counter Timer (AT) is an advanced technology based unit designed around eight bit microcontroller. It has three modes of data storing namely, Preset Scaling, CPS & CPM modes. Readings upto 1000 readings can be stored and recalled on to the LCD dotmatrix display. The data counts can be printed directly onto a printer through printer port or downloaded into a PC through serial port under software control.

Gamma Ray Spectrometer GR 611M manufactured by NUCLEONIX is useful for obtaining the spectrum of Gamma isotopes.

This system is very useful for doing experiments in academic institution & universities in teaching & research labs. System applications in research labs, PC-CT centres, medical cyclotron facilities where in users may prefer to use the system with well type scintillation detector. Also it finds applications in Nuclear medicine, Nuclear research labs, Health Physics labs, Environmental survey labs etc., for sample counting for gross gamma activity.

For all these applications initially systems is to be calibrated by operating SCA in window mode (WIN) & scanning for each of the standard isotopes such as Cs-137, Co-60, Ba-133 etc. Once calibrated, user can set the SCA, mode to NORMAL (NOR) mode and select LLD & ULD to bracket for the required energy band, and count the sample under study.

**(B) FRONT VIEW OF MINIM BASED GAMMA RAY
SPECTROMETER TYPE : GR 611M**



(C) SPECIFICATIONS

The Gamma Ray Spectrometer (Micro controller based) Type GR 611M consists of a MINIM based modular counting unit and a Scintillation Detector Type: SD151/152/153W. The Spectrometer can also be used for Gamma Counting applications. This MINIM based system has added advantage of savings in cost and also conserves bench space because of its optimal design.

This system is configured around MINI BIN and Power Supply Type: MB 403 with the following Modules:

High Voltage Unit Type: HV 502

Linear Amplifier Type: LA 520

Single Channel Analyzer Type: SC 530

and Counter Timer Type: CT 541A (Micro controller based), having unique built-in user programmable features for data acquisition & data outputting.

NIM INSTRUMENTATION BIN:

Interchangeability	:	Mechanical Tolerances are in accordance with TID 20893 (Rev)
Panel dimensions	:	Standard rack 8 3/4 inches high and 11 3/4 inches wide (without flanges)
Depth	:	12 3/4 including heat sinks
Module connectors	:	8 NIM connectors per bin at the panel as specified by TID 20893 (Rev) or 24 pin of Amphenol connectors (for use in INDIA)
Installed wiring	:	All connectors of MINI BIN are wired in parallel for +12V,-12V,+24V and -24V, high quality GND and power return GND
Construction	:	Bin is constructed with two side aluminum flanges with casted handles, top and bottom S.S. Rod spot welded mesh supported with two aluminum bars at top and bottom, module guides with S.S. rods and connector plate at the back. All these parts are anodized /painted completely. The channels are milled; spot welded S.S. rod guides provide precisely smooth and easy movement of modules into the bin.
MINIBIN enclosure dimension	:	14" wide X 10" height x 11.5" depth without accounting handles and heat sinks

POWER SUPPLY MB 403:

Input voltage	:	230V AC \pm 10% AC
Frequency	:	50Hz
Stability	:	For +/- 12V & +/- 24V, +/- 0.3% over any 24 Hours period at constant ambient temperature. Over the combined range of no load to full load and specified mains variation after 60 min.
Temperature range	:	0 to 50° C ambient
Temperature coefficient	:	0.02% per o C over 0 to 50° C ambient.
Noise and ripple	:	for +/- 12V & +/- 24V, 20mV peak to peak
Regulation	:	Better than \pm 0.5%
Voltage adjustments	:	+/- 2% minimum range. Reset ability +/- 0.5% of supply voltage
Recovery time	:	+/- 12V & +/- 24V outputs will recover within +/- 0.1% of steady state values within 100 sec following any change in specified line Voltage or between 10 to 100% full load.
Circuit protection	:	a) Input of the supply is protected by two fuses b) Output of the power supply is short circuit and overload protected by means of fold back electronic circuit. c) Recovery is automatic when overload or short circuit is removed. d) Continuous short circuit will not damage the power supply Unit.

HIGH VOLTAGE UNIT TYPE: HV 502

- Output voltage variable continuously from 0 to 2000 volts.
- Output current (maximum) 1mA.
- Load and Line Regulations: better than 0.05% of full scale
- Indefinite overload and short circuit protections and self-recovery.
- Output ripple less than 50 mV
- Dimensions: Two bit Module.
- HV is adjustable by ten turn helipot with knob.

LINEAR AMPLIFIER TYPE: LA 520

- o **Input Polarity** : **Positive / Negative**
- o **Total Gain (Typical)** : **250 (approx.)**
- o **Output (Unipolar/Bipolar)** : **0-8V (usable recommended linear range)**
- o **Max. Output (Bipolar)** : **10V (Saturation Level)**

4. SINGLE CHANNEL ANALYSER TYPE: SC 530

- o **Input** : **Unipolar or Bipolar with a +ve leading edge 0 to 10V**
- o **Pulse Pair Resolution (approx.)** : **1 μ sec**
- o **Output Pulse Polarity** : **Positive**
 - Pulse Amplitude** : **+5V**
 - Pulse Width** : **1 μ sec**
- o **LLD output pulse amplitude** : **+5V**
 - Output pulse width** : **1 μ sec**
 - LLD/Base line variable by** : **10 turn helipot / Dial**
- o **Window width** : **Continuously variable by helical potentiometer / Dial**
 - Window** : **0-1V in WINDOW mode**
 - ULD range** : **0-10V in NORMAL mode**
- o **Dimensions of module** : **1 Bit**

COUNTER TIMER TYPE: CT 541A

- **Input** : **100 mV to 10V, unipolar or positive bipolar semi Gaussian / Gaussian pulse**
- **Pulse width** : **1 μ sec (min)**
- **Polarity** : **Positive or Negative**
- **Input Impedance** : **10 K ohms**
- **Input counts capacity** : **999999 counts**
- **Pulse height** : **100 mV to 10 V by a preset provided on front panel**
- **Discriminator** : **16x2 LCD dot-matrix display has been provided to indicate data counts & Elapsed time**
- **Display** : **0-9999 seconds**
- **Preset time** : **START, STOP, PROG, STORE, INC & DEC command buttons have been provided on the front panel key board**
- **Command Buttons** : **(a) Counts for a preset time (b) CPS (c) CPM**
- **Modes of Data Acquisition** : **Programmable through switch control buttons**
- **Preset Time Selection** : **Up to 999 readings**
- **Data storage** : **includes selection of preset time storing / recalling of data, starting and stopping of acquisition, label assignment for data counts such as BG (background), ST (standard) and SM (sample).**
- **Programmability** : **This module has built in parallel port for Data transfer**
- **Printing option** : **This module additionally has built-in RS232C serial port for downloading the data into PC.**
- **Serial port**

(D) ACCESSORIES

SCINTILLATION DETECTOR (S) :

Scintillation detector with flat type NaI crystal of 1"X1" / 2" X 2" /3" X 3" /well type detector of 2" X 2" or 3" X 3" of NUCLEONIX make or its equivalent is compatible to GR611(I). The output of these units (taken from preamplifier) is POSITIVE for all Nucleonix make Scintillation detectors.

Hence the input polarity of the amplifier in GR611M (I) is to be selected for POSITIVE. Required LV supply of -12V for the scintillation detector, is drawn from the GRS rear panel through a LV cable. Also the HV bias supply for the PMT of the detector assembly is drawn from GRS, HV module. Preamplifier of the scintillation detector is a charge integrating type of preamplifier.

Nucleonix Systems offers wide range of NaI Scintillation Detectors of different sizes both with flat & well type crystals, to meet the requirements of wide range of users for Gamma ray spectrometry measurements.

Scintillation detectors offered include 1"x1", 2"x2" & 3"x3" NaI integral assemblies with built-in pre-amplifiers. These detector assemblies give excellent stability, superior performance & good resolution in the range of 8.0 to 9.5% for Cs-137. Scintillation detectors of other sizes can also be offered against user specific requirements



GAMMA REFERENCE STANDARD SET TYPE GS 290

Gamma Reference Standard Set Type: GS290 consists of a set of FIVE Gamma sources evaporated & sealed on 25mm dia x 5mm plastic disc covering SIX photo peak energies in the range of 2 to 5 micro curie. A reference chart for this is given below. The accuracy of these sources is in the range of +/-10%. All these disc sources are enclosed in a box made of polished wood acrylic sheet and supplied.

Isotope	Energy MeV	Nominal activity	Half life
Co-57	0.123	2-5 μ Ci	273 Days
Ba-133	0.36 (Main)	2-5 μ Ci	7.5 Years
Na-22	0.511; 1.280	2-5 μ Ci	2.6 Years
Cs-137	0.662	2-5 μ Ci	30 Years
Co-60	1.17; 1.33	2-5 μ Ci	5.3 Years



LEAD CASTLE FOR SCINTILLATION DETECTOR -LS 250

This consists of 40mm lead shielding cylindrical rings assembled according to the detector. There is a provision in the bottom ring through which system connections are given to the detector, which is placed in the lead shield.



1- Inch detector (8 lead assembling parts)



2 - Inch detector (9 lead assembly parts)



3 - Inch detector (10 lead assembly parts)

The top ring has a holding knob through which sample can be loaded on to the scintillation detector, and this closes the lead castle from top side.

CHAPTER - II

FRONT PANEL & REAR PANEL CONTROLS

A. CONTROLS ON POWER SUPPLY MB 403

All the controls of MINIM BIN are on the control strip of MB 403.

- POWER ON : DPST switch, to switch "ON" the mains supply to the instrument. Presence of mains supply is indicated by the pilot lamp.
- VOLTAGE TEST POINTS : These are sockets for monitoring of the power supply output voltages +/-12V, +/-24V and GND marked against each sockets.
- LV SOCKET : A 5-pin circular I/O connector or 9 pin D type connector. This Connector contains all the low voltages of the power supply and is meant to draw power for ancillary equipment such as a pre-amplifier of a Scintillation detector.
Electrical connection details are given in a separate drawing at the end.
- OUTPUT CONNECTORS : There are six, 24 pin connectors Type : 202516-3 or 24 pin Amphenol type of rack and panel connectors mounted on the rear plate of the bin, wired in parallel and providing the power to modular units. Pinout details of the connections are given separately.
The 24 Pin output connector provides all the LV's with their sense points and GND, The details of which are given at the back.
For fuses, voltage, current and over voltage protection adjustment, please see at the end detailed manual. LV output connector (on rear panel) either 9-pin D connector or a circular I/O connector is provided. This may be required for providing LV supplies to Scintillation detector.

B. OPERATIONAL CONTROLS OF HV 502

- "ON" SWITCH : This is a toggle switch to switch ON the HV.
- EHT OUTPUT : This is a MHV Socket or UHF socket for draw in the EHT output to the required load.
- EHT ADJ. : EHT output can be set to desired value by a ten turn helipot with knob.
- EHT INDICATION : EHT indication by ten turn dial calibrated in-terms of EHT.
- EHT POLARITY : User can select either POS or NEG polarity for EHT, by reversing the polarity PCB sitting on the main PCB inside the unit. By default POS polarity is set.

C. OPERATIONAL CONTROLS OF LA 520

- ATN : x2.5, x1 are provided, By default x1 is set.
- PZ : Pole Zero adjusted Intime constant of 0.5msec
- POLARITY : Toggle switch for the polarity of the input pulse. (For all Nucleonix make Scintillation detectors, it is to be set at **POS** position).
- GAIN
- COARSE : Rotary control to vary the gain of the amplifier in 6 steps viz. 0.2, 0.5, 1, 2, 5 & 8.
- FINE : A ten turn helipot control for continuous variation of the gain of the unit.
- TIME CONSTANT : Rotary controls providing a choice of six differentiation and integration time constants. Time constant is variable viz. 0.5, 1, 2, 3, 6 & 10. By default, it is set to 1.
- INPUT : Co-axial BNC connector for feeding the input pulses to the amplifier from the Scintillation Pre-amplifier output.
- OUTPUT : Co-axial BNC connector providing the output pulses from the amplifier, to single channel analyser.

D. OPERATIONAL CONTROLS OF SC 530 : Controls on Front Panel

MODE : Three way rotary controls to select any one of the three modes of operation.

INT : In the integral mode, the pulses of amplitude exceeding the base line (LLD) setting will be made available at the output. ULD is ignored in this mode.

WINDOW : In the "Differential" mode the unit is operated as a high resolution narrow window of 1 volt analyser. Therefore pulses exceeding the base line setting and within the window setting mode will be available at the output. In this mode LLD is called as BASE LINE.

NORMAL : In this mode the upper level and the lower level helical potentiometers are independently variable from 0 to 10 V and an output is generated for pulses analysed between the levels. This mode is useful for wide window applications.

LOWER LEVEL DISCRIMINATOR : Ten turn potentiometer to vary from 0 to 10V

UPPER LEVEL DISCRIMINATOR / WINDOW : In 'NORMAL' mode this control is called ULD and this gets triggered when the input pulse height is above the ULD setting. Dial corresponds to (0-10V) for ten turns. SCA output is allowed if the input pulse height is below the ULD setting. In 'WINDOW' mode this control is called WINDOW and ten turns variation corresponds to (0-1V) i.e., one turn is equal to 100mV window. WINDOW is usually set to one turn (100mV) for scanning of an isotope for its energy Vs Countrate output. This window always overrides on the baseline.

NORMAL MODE OF ANALYSIS : This mode of operation is recommended when the user wants to count a wide energy band of any isotope. Both LLD & ULD corresponds to (0-10V) for ten turns and user can bracket the region of interest and count the sample. In this mode SCA gives output for each of the input pulses lying above LLD and below ULD.

INT MODE OF ANALYSIS : This is integral mode of operation SCA generates output for all the input pulses just above the LLD threshold. It ignores the ULD setting. Any application requiring this kind of situation, user can set to this mode.

WIN MODE OF ANALYSIS : This mode of operation is recommended when the user wants to calibrate the Gammaray spectrometer or when one would like to scan the gamma spectrum of an isotope or wants to counts for a narrow band of energies.

In this mode LLD is called 'Base line' and ten turns corresponds to (0-10V). ULD is called WINDOW & ten turns corresponds to (0-1V). That means each turn corresponds to 100mV Window. In this mode window overrides (sits) on the baseline and all the input pulses above baseline and within the window set are counted. SCA gives output for pulses between (BASELINE) and (BASELINE+WIN).E.g. If baseline is at 1.0V (Dial at 1.0) & WIN dial at 1.0 (100mV window). For input pulses above 1.0V but below 1.1V, SCA output is generated.

INPUT : BNC connector for feeding the input to the analyser

OUTPUT : BNC connector providing the output of the analyser

E. OPERATING CONTROLS OF CT 541A

i. FRONT PANEL CONTROLS AND INDICATIONS

POLARITY SWITCH

Positive & Negative : Selects the polarity of the input signal for counting.

INPUT : It is a BNC receptacle which receives the input pulses to be counted.

DISC : CT541A has a pulse height discriminator (trimpot) with variable bias from 100 mV to 10V which is normally set to approximately 200mV, by default.

INTELLIGENT KEY PAD

- (a) PROG key button : This key facilitates the user to programme the operation of the instrument in different modes / conditions. More details are covered under forthcoming section "Instructions on Intelligent keypad commands".
- (b) START key button : This is used for starting of acquisition and printing. After all the programme parameters have been set.
- (c) STOP key button : This key can be used to terminate acquisition and printing in between. In the normal course, acquisition will stop automatically at the end of preset time and the data printing will stop once the end serial number setting for printing has reached.
- (d) INC/DEC key button : These keys are used while setting the programme parameters to increment and decrement a value or to change the option selected to another value.
- (e) STORE key button : This key is used for storing the readings or data values, in the manual mode of storing only.

At the end of acquisition for a preset time, if user presses this button, data counts will be stored and the sl.no. in the display increments to the next value.

In CPS/CPM modes, CPS/CPM is saved on pressing this button.

LCD DOTMATRIX DISPLAY

This is a 16 X 2 alpha numeric LCD dotmatrix and responds to all the commands from the keypad and displays programme parameters, data counts, preset and elapsed times.

TO PRINTER : This is a 25 pin D-female connector through which one can connect a printer (with centronics interface cable) for direct printing of data.

SERIAL PORT (RS232) : This is a circular I/O connector having RS232 compatible signals for serial data communication to a P.C. Under software control from a PC, the stored data readings from this unit can be downloaded into PC.

INSTRUCTIONS ON INTELLIGENT KEYPAD COMMANDS

User can go through these and have some practice before he can really use the system
When we switch on the unit, the display will show up,

COUNTER *
TIMER * AT for 3 Sec.

NSPL HYD for 3 Sec.

1. ACQUISITION MODE SELECTION

By default, display changes to,

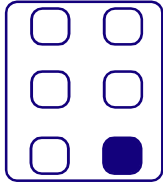

ACQ MODE
PR.TIME

This signifies that by default "acquisition is in preset time mode". Because in majority of the situations counting is done for a preset time set.

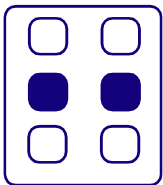

If you want other modes of acquisition such as CPS (Counts per second) or CPM (Counts per minute) then press increment or decrement keys to select required mode or else proceed as follows. If ACQ MODE is required by PR. TIME then, skip the above selection and proceed as given below.

2. PRESET TIME SETTING

By pressing PROG key, display changes to,

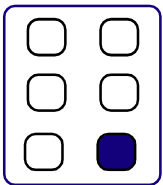

PR
TIME XXXX

Cursor position

This displays the previous preset time for counting. We can change the preset time by the following way.

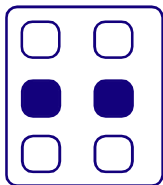

Increment Key can be used to increase the value at the cursor position.

Decrement Key can be used to shift the cursor position to the left.

By the above method set the required PRESET TIME for acquisition.

* Now steps (4.2.3), (4.2.4) & (4.2.5) as given below can be skipped by ****Normal users.** One can keep pressing "PROG" key till you fine

SAVE?
(PRG)

This signifies that the set (programmed) parameters and their values are to be saved for operation of the equipment. User can save the parameters by pressing increment or decrement key. If these parameters are not saved, system will take and work according to the earlier programmed parameter.

Once programme parameters are saved user will find the display as

SAVE?
(PRG) OK

Now the user can go for starting of data acquisition as mentioned under 4.2.13.

** Normal users : Those who teach or do laboratory experiments.

Steps (4.2.3), (4.2.4) & (4.2.5) have been provided as additional programming features for researchers/other users in DAE & NPCIL etc.,

3. **SETTING OF STARTING SL.NO. OF 'DATA READING' FOR ACQUISITION AND OUTPUTTING TO DISPLAY / PRINTER**

Now by pressing PROG key again display changes to,

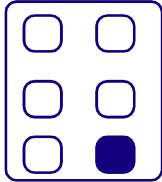

SL.NO. ?
A/O XXXX

This displays the current serial number for storing and to recall data readings. We can change serial number by similar method, as explained under preset time setting.

A/O :

Acquisition & outputting to recall, store and print from starting number.

4. **LABLE ASSIGNMENT FOR A DATA READING**

Lable assignment is required and will be quiet useful for Researchers and Health physicists who may be counting Beta/Samples or research samples. They will record background count, a reading with standard source and followed by this number of readings with different samples. So, a feature for lable assignment has been added in the micro controller software,

BG = Background

ST = Standard

SP = Sample

Before acquisition for each reading lable is to be assigned. If same lable is to be continued after a particular assignment, then user need not do any thing, the same lable will continue till such time one changes it.

By default may have data values assigned with 'No Lables' or previously assigned lables.

By pressing PROG key, display changes to,

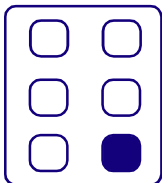

LABLE
XX

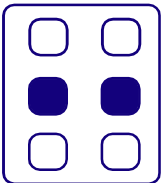

XX :

Lable can be changed by using inc or dec keys, options are SP (Sample), ST (Standard), BG (Background) and ■■ (No lable).

5. ITERATION PROGRAMMABILITY FOR A READING

Iteration programmability is another useful feature that has been provided. Sometimes user may like to iterate a reading 2 or 3 times. The system allows this and it displays averaged reading only, at the end of two or three iterations. Acquisition for iterations once initiated will go till all the iterations are completed. Users intervention is not required.

By pressing PROG key, display changes to,

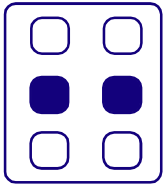
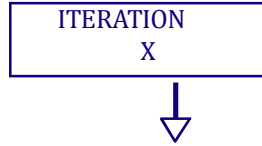
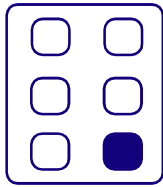

By default '1' is displayed. Number of iterations can be changed by using increment or decrement keys.

6. SAVING PROGRAMMED PARAMETERS

All the programmed parameters are to be saved by the user before he can start acquisition. Without saving, the system will use the previous parameters for acquisition.

By pressing PROG key, display changes to,

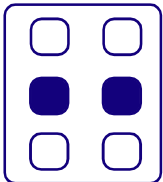
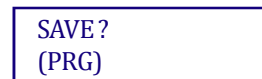
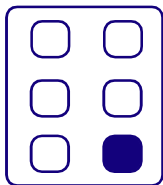

SAVE?

To save the above parameters press increment or decrement keys

"OK" will be displayed on saving of parameters (PRG)

7. RECALL DATA READINGS

This is a very useful feature that has been provided in this unit. At the end of storing/saving of a set of readings, this feature will enable the users to recall the readings on to the display, from the S.No. set in the "RECALL" mode. Changing of the S.No. is similar to that explained under "PRESET TIME" selection.

By pressing PROG key, display changes to,

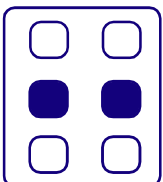
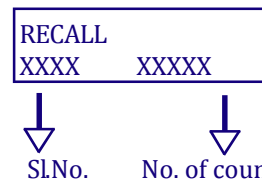
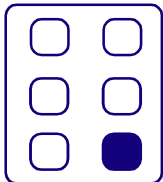

Recall serial number can be changed by increment or decrement keys.

8. PRINT COMMAND FOR DATA READINGS PRINTING

After setting the limits for Sl.No. both for start & end, printing can be carried out by invoking this command. It is assumed that a **centronics interface compatible printer** has been connected to this counting system through a cable.

A sample print out is enclosed in the following page.

By pressing PROG key, display changes to,

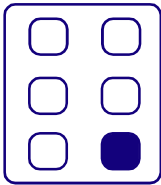

PRINT?
DATA

Press START to print the data. Starting number can be selected by Sl.No. setting, last number can be selected by

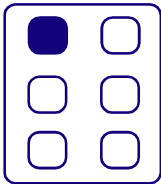

END
PRINT ?

9. STORING OF DATA READINGS

This system has CMOS memory to store upto 1000 readings. Storing can be initiated in two ways.

- (a) MANUAL
- (b) AUTO

User can select any of these options. In manual mode at the end of acquisition of each reading the user has to press "STORE" command button once for each reading.

In AUTO mode, each of the data readings gets saved into memory along with label. User intervention is not required.

While acquisition is going on, user may observe that at the end of each acquisition, the Sl.No. pointer will be incremented by one the data counts will be stored.

By pressing PROG key, display changes to,

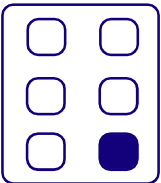

STORE (D)
AUTO

Default mode is AUTO, to change to manual mode press increment or decrement key. AUTO mode is used to store data automatically after acquisition (PR. TIME).

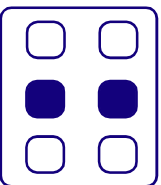

Note : In case of CPS/CPM mode press STORE to store data at any time. AUTO storing is not valid in CPS/CPM mode.

10. DATA ACQUISITION BY PRESING START BUTTON

Once the user presses 'START' at the end of saving of programmed parameters, user will see a display as,

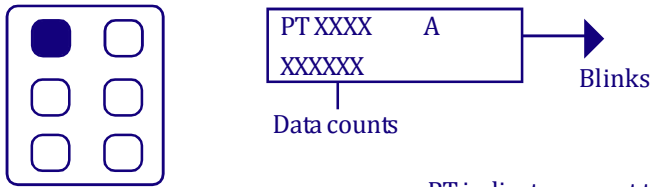

PT indicates preset time

Below the preset time data counts will appear. "A" at the end of preset stands for Acquisition and blinks during acquisition and disappears at the end of acquisition. The counts will get stored at the particular SI.No. if STORE mode is in AUTO condition. If the STORE is in manual mode, the counts acquired can be stored by pressing STORE button. The count will not be stored if START button is pressed again. Hence this can be viewed as fresh iteration.

Menu	Options
ACQ mode	Pr. Time
	CPS
	CPM
Preset Time	----
SI.No. (A/O)	----
Label	■■
	SP
	ST
	BG
Iteration	1 / 2 / 3
Save? (PRG)	OK / skip
Recall	----
END NO. (PRINT)	----
PRINT DATA	----
STORE DATA	AUTO
	MANUAL
HV	----

CHAPTER - III DEFAULT SETTINGS

Default settings with Gamma Ray Spectrometer set are to, adjust the Cs-137 photo peak at 3.0K base line. This is primarily done to cover Gamma Ray Spectrometer energy band from 60keV to 2.0MeV, for counting of samples. Setting the Cs-137 photopeak can be around 3.0V (not necessarily at 3.0V exactly).

High voltage (HV502) : 600 - 750V adjustable

Linear Amplifier (LA520)

Fine gain : Ten turn dial with lock
Coarse gain : 2
Shaping : 0.5 μ sec
ATN : x1
Polarity : POS (+ve)
UNI/BI : UNI (Unipolar)

Single channel analyser (SC530)

ULD/WIN : 100mV (1turn)
LLD : Variable
MODE : a. WIN - for scanning & energy calibration purpose
b. NOR - for wide windowed counting, after selecting required band of energy by bracketing with LLD & ULD discriminators.

Counter Timer (CT541A) : Polarity - +ve (POS)

IMPORTANT NOTE :

When you operate the instrument with default settings, as indicated above & count with Cs-137 source, Cs-137 photopeak will appear around \simeq 3.0V base line of SCA

CHAPTER - IV

BLOCK DIAGRAM DESCRIPTION

Refer to the block diagram, given in Fig. It consists of Scintillation Detector SD 151 or its equivalent, High Voltage unit HV 502, Linear Amplifier LA 520, Single Channel Analyzer SC 530 & Counter Timer CT 541A. All these modules are housed inside Minibin and Power Supply Type: MB403. Minibin and Power Supply provides low voltage supplies +/- 12V & +/- 24V to these modules. The Scintillation Detector is coupled to the main electronics unit. The assembly of scintillation detector and main electronic unit is called as Gamma Ray Spectrometer. This unit is essentially used for studying the Gamma Ray Spectra of Gamma isotopes.

SCINTILLATION DETECTOR

It consists of a Sodium Iodide crystal optically coupled to a photomultiplier. It has three connectors, UHF, circular I/O or Minihex & BNC connector. The high voltage (operating voltage) required for the detector is fed from the HV module and is connected to the UHF connector. Minihex / 5 pin I/O connector is used to feed in the low voltages to pre-amplifier from Minibin power supply. The output of the detector is given to the linear amplifier input through a BNC cable. Scintillation detector of NUCLEONIX make or its equivalent can be connected to NUCLEONIX Gamma Ray Spectrometer electronic unit.

HIGH VOLTAGE UNIT (HV 502)

It is basically a two-bit module which generates 0 to 2000 V. It has HV out (MHV connector) and the ten turn dial / helipot for changing the EHT continuously from 0 to 2000 V. It can deliver up to a maximum current of 1mA. Line & Load regulation is better than 0.5%. HV indication is provided on a three and half DPM. Output from the HV 502 is fed to Scintillation Detector through a MHV to UHF cable for biasing of the detector. Typically detector bias can be from 500V to 800V.

LINEAR AMPLIFIER (LA520)

Linear Amplifier LA 520 uses solid-state/Integrated circuits extensively in its design. Featuring excellent non-overload characteristics, a high gain, low equivalent input noise and flexibility of pulse shaping, LA 520 is ideally suited for use with Nuclear Counting Systems such as Gamma Ray Spectrometers and other similar units.

SINGLE CHANNEL ANALYSER (SC 530)

Single Channel Analyzer receives the input from Linear Amplifier LA 520 output. SC 530 essentially scans the input pulses for differential pulse height analysis and gives out TTL output pulses for the windowed pulses. Output from SC 530 is fed to Counter Timer CT 541A for counting purpose. SC530 can be operated in three modes as described previously.

COUNTER TIMER (CT541A)

Counter timer CT 541A is a two-bit module. It can count the events for a preset time. Elapsed time and counts are indicated on the 16x2 LCD displays. Input can accept pulses of POS or NEG polarity of unipolar / bipolar or TTL pulse. Counter timer CT 541A has keypad buttons for operation and is designed around a microcontroller. It can acquire data in three modes of operation namely

- a. Preset Scaler
- b. CPS
- c. CPM.

Readings up to 1000 can be stored and recalled onto the display. The unit has built-in printer port for direct data printing and serial port for downloading of data to PC.

FIG. BLOCK DIAGRAM OF MINIM BASED GAMMA RAY SPECTROMETER

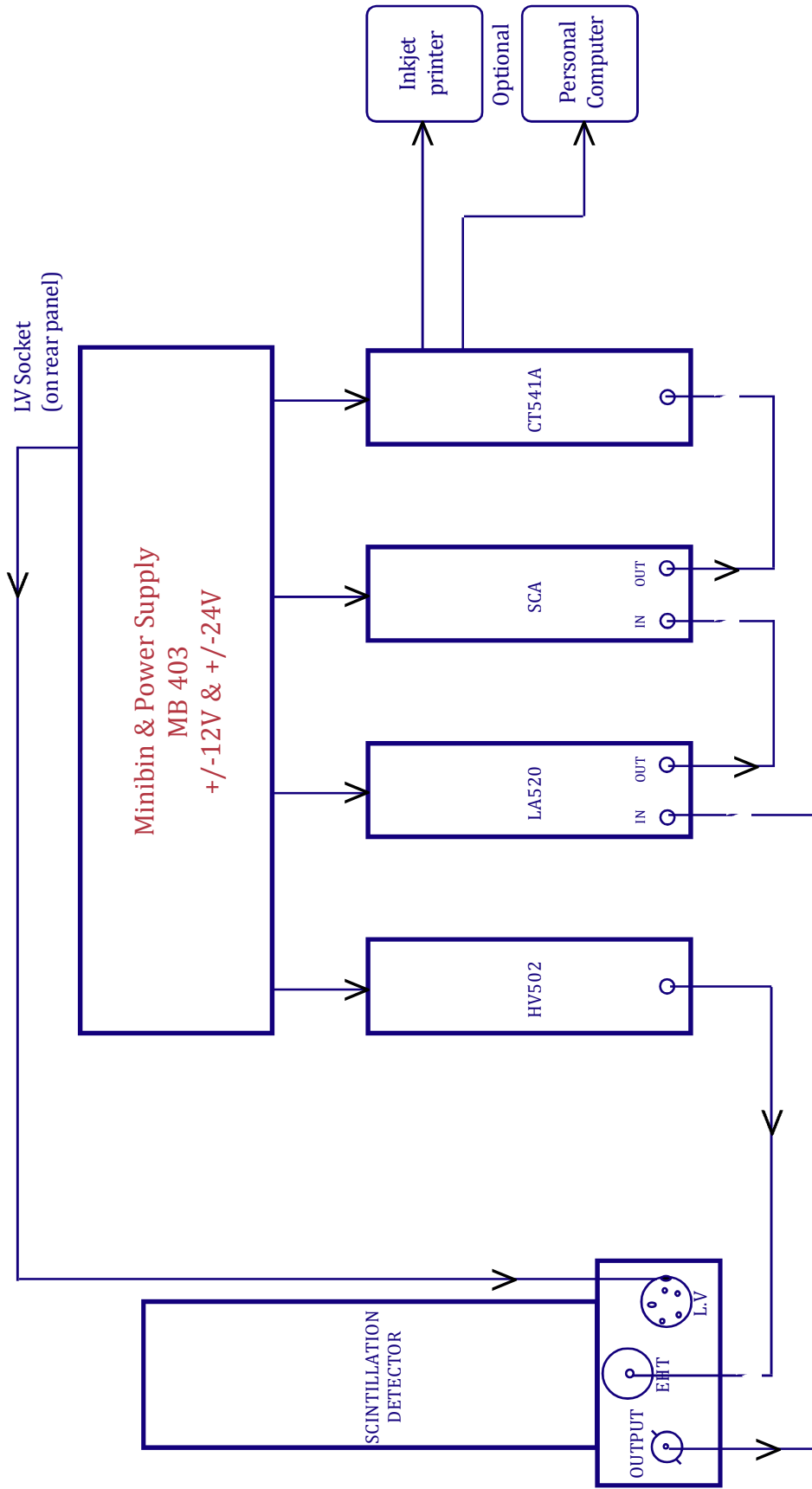

B. SYSTEM INTERCONNECTIONS / INTEGRATION

For system interconnections, please refer to the interconnection table given on the following page.

The other optional accessories that can be connected to this system are an Inkjet printer which can be used for printing data counts stored. Also a PC if user wants to download the data into PC.

Essentially the following cables are used :

1. UHF to MHV cable 01 No
2. LV cable (5 pin I/O connector) 01 No
3. Signal cables (BNC to BNC) 03 No

Required for interconnection.

OPTIONAL CABLES

4. Printer cable 01 No
5. Serial port cable 01 No

Usually the Gamma Ray Spectrometry System GR611M is shipped / despatched with all the modules and power supply module plugged into MINI bin. If for some reason all these modules of GRS are packed and sent separately then the user is requested to integrate them (please refer to front panel picture of the system).

GAMMA RAY SPECTROMETER (MINIM BASED MODULAR) SYSTEM INTER CONNECTION DETAILS

S.No.	Type of Cable	Signal from	Signal to
01.	UHF to MHV EHT cable	EHT output MHV socket on HV 502	Scintillation detector UHF socket
02.	LV cable with two end 5 pin female circular I/O connectors .	Mini-hex / 9 pin of D or circular I/O from rear panel of Minibin	Scintillation detector Mini-hex socket/Circular I/O connector
03.	Signal Cable (BNC to BNC) 1 or 1.5 meter long	Scintillation Detector (O/P BNC)	I/P BNC recepticle on LA520
04.	Signal Cable (BNC to BNC) 0.3 or 0.5 meter long	OUTPUT BNC recepticle on LA520	I/P BNC on SC530
05.	Signal Cable (BNC to BNC) 0.3 or 0.5 meter long)	OUPUT BNC recepticle on SC530	I/P BNC on CT541

OPTIONAL CONNECTIONS

06.	25 pin D-25 pin D cable	CT54 1A rear panel	Inkjet printer
07.	3/5 pin circular I/O connector to 9/25 pin D-connector	CT54 1A rear panel	PC Serial Port

CHAPTER - V

OPERATING INSTRUCTIONS

Before using the GAMMA RAY SPECTROMETER(GR611M) system for Normal testing user has to follow the instructions given below.

1. Make sure all modules are inserted into the bin and module screws are tightened properly. All dials, rotary switches, toggle switches, BNC sockets are in good condition.

2. If any damage happened to the system, report the matter immediately to:

Customer Support Division
NUCLEONIX SYSTEMS PVT. LTD.
Plot No. 162 A & B, Phase II,
I.D.A. Cherlapally, Hyderabad - 500 051.
PHONE : + 91-7207034546, + 91-7331104481, 7331104482.
e-mail : info@nucleonix.com

3. Before switching ON the system keep all the controls to default settings as mentioned below.

- a. High Voltage Unit (HV502)

i. toggle switch to OFF position

ii.

HV adjust knob at complete anti-clockwise direction

- b. Linear Amplifier (LA 520)

i. Fine gain : Medium
ii. Coarse gain : 1
iii. Shaping : 0.5 μ sec
iv. ATN : x1
v. Polarity : POS (+ve)
vi. UNI/BI : UNI (Unipolar)

- c. Single Channel Analyser (SC 530)

i. MODE to 'WIN'

ii. LLD/Baseline dial to 'min' position

iii. ULD/Window dial to 1.0 (= 100mV)

- d. Counter Timer (CT 542A)

i. Polarity to 'POS'

4. Now place the Scintillation detector closely onto the left of the MINIM Gamma Ray Spectrometer unit. If Lead Castle is ordered, then assemble the Lead Castle by placing the Scintillation detector inside the lead shielding (for details on assembly refer to the Lead Castle LS240 folder/manual).

5. Switch on the Mini Bin & Power Supply (MB403) and check dc voltages at the test sockets on the front panel of the MB403 stip.

If all dc voltages are proper, switch OFF & make interconnections from Gamma Ray Spectrometer to Scintillation detector as per 'Interconnections Table'.

If dc voltages are not observed in all the sockets, check for the mains fuse on the rear panel of MB403 power supply module. If found defective it is to be replaced. Any problem beyond this contact our Customer Support Division's advice.

6. Switch On the system, and then switch ON the High Voltage unit(HV502).
Apply the high voltage to the detector by rotating the HV knob /ten turn pot in the clock wise direction.

Note that EHT Output = Dial Set * 200

& set the HV to 'OPERATING VOLTAGE' of the Scintillation detector (It is mentioned clearly on the detector.)

7. Place source (Cs-137) on top of the Scintillation detector, observe the Linear Amplifier output in a good oscilloscope(50 MHz/100 MHz) in 1V / DIV sensitivity.
8. Now adjust the 'Attenuation' (reduce if required) or slightly the fine gain knob such that the photopeak amplitude (ht) of CS-137 as observed in the oscilloscope is in the range of 2.5V to 3.0V. (For this output of linear amplifier LA520 is to be fed to oscilloscope)
9. Now restore LA 520 output connection to SC 530 and scan for the gamma spectrum of Cs-137 isotope by taking the readings. For this vary the BASELINE (LLD) control dial in steps of 10 small divisions (which is equal to 100mV) starting from 0.00, 0.10, 0.20, 0.30..... etc., one would observe peak counts, between 2.9V & 3.0V baseline setting.
Here for each SCA setting, counts are stored in CT542A for a preset time of 10 to 50 sec or as desired by user. For programming and using CT542A refer to the keypad command instruction in detail.
10. From the above readings stored/acquired user can find out the resolution of the Scintillation detector, for Cs-137 (Refer to Chapter IV(b) for more details and one can find linearity of the spectrometer by placing other isotopes and counting)
Once the above is carried out the spectrometer is calibrated and is ready for use. At this stage user will have information on Energy Vs Baseline voltage from the linearity graph.
If the system is acquired for any sample counting of a specific energy, then using the standard source of that energy, select the entire photopeak area by using LLD and ULD knobs on the front panel of SC 530 and keep the system in Normal mode of operation.
For sample activity purpose full photo-peak area should be counted. Full photo-peak can easily be covered in the Normal mode of operation.
If the photo-peak is the narrow width, then it may be possible to bracket the photo-peak in WIN mode also, provided photo-peak full width is less than 1V. Thus counts obtained will be proportional to the sample activity for that particular energy. Bracketing of Half-width of the photo-peak may give incorrect results and is not advisable.
11. Now user can place his actual sample for counting.
 - a. If it is a known energy then select the LLD & ULD & MODE (either NOR for wider energy band counting, WIN mode for narrower energy band counting) appropriately and do the sample counting.
 - b. If it is unknown energy one has to scan the entire range by operating in WIN mode then identify the energy band, after which actual sample counting could be carried out.
12. This system has the facility for connecting to a printer for data printing and also data readings can be downloaded into PC. (For details on this please refer to Instruction manual on Counter Timer CT542A).

Also the readings could be saved at the end of each acquisition and recalled back on to display for visualisation.

CHAPTER - VI

AVAILING OF MAINTENANCE/ CALIBRATION SERVICES AND WARRANTY CLAUSE (with in India)

6.1 GENERAL

As per the warranty clause of the company, we provide one year warranty during which period we provide free service at our works. Hence in case of any mal-function in our instruments, you are requested to send the unit back to our works by RPP/COURIER/SPEED POST PARCEL/GATI/XPS/door delivery. We shall arrange immediate rectification/replacement within two weeks from the date of receipt of the equipment at our place. Please note that the equipment will be serviced at our works only.

The equipment is to be sent to:

The Servicing Department.

NUCLEONIX SYSTEMS PRIVATE LIMITED.

Plot No: 162 A & B, PHASE II, I.D.A. Cherlapally, Hyderabad - 500 051.

Phone: + 91-7207034546, 68888777.

Mobile No: 7331104480, 7331104481, 7331104482, E-mail: info@nucleonix.com.

For all the Radiation monitoring equipment, detectors built-in or external probes will not have one-year warranty, but only inspection warranty at the time of supply is provided. Since detectors will / may have fragile glass construction, we do not provide warranty. In case of failure of these components, Nucleonix will supply detector replacement at cost-cost price.

Note: In respect of all types of portable radiation monitors, it may be necessary to checkup and recalibrate the equipment once a year at our works.

6.2 EQUIPMENT REPAIRS / SERVICING POLICY (WITH IN INDIA)

(a) During Warrantee

The following procedure is to be followed by the customers with in India for availing services/ repairing facility during warrantee period.

Equipments are to be sent to our works for availing free repair services during warrantee, after the customer receives approval from the customer support division, by sending an e-mail.

For all equipments, costing less than 6.0 lakhs one year warrantee & free service is offered, when the equipments are sent to our works only. For larger systems such as installed systems, networked systems, specialized systems, costing more than 6.0 lakhs during one year warrantee, free service is offered at site. Field service Engineer will be deputed subject to warrantee terms & conditions.

This does not include personal computer related problems, for which local computer service provider of the PC vendor is to be contacted. Also for software related problems online support will be provided. Software support doesn't include cleaning of virus problems etc.

When the equipments are sent to our works for warrantee services, they are to be properly packed with adequate cushion to prevent any transportation damages. Nucleonix Systems is not responsible for damages or loss during transportation.

Packing / Freight charge is to be borne by customer when he sends the equipment to our works. However when we return after servicing packing will be Nucleonix responsibility & Freight charges will be to your account. Only services are free.

Please indicate in your correspondence equipment model & serial number.

All the equipments are to be sent to our works only on door delivery basis.

For Door Delivery Transportation contact XPS/GATI cargo in your city / town or a reliable courier service to pick the consignment from your place. For their nearest local address & phone no's look into their websites. Transit insurance if the customer feels is necessary it is to be covered.

Nucleonix Systems will not receive the equipments sent by other modes of transportation, such as Rail/Road.

After servicing, equipments will be sent back by same mode of transport such as XPS/GATI/COURIER/RPP.

All types of Radiation detectors, glass ware, PMTs etc which are fragile are not covered in warrantee, if the failure is due to physical damage, external or internal due to shock, dropping, miss-handling etc. If the failure is due to a natural fault then only it is covered under warrantee for a limited period of three months. However complete electronics is covered for 1 year warrantee. You can also send the equipment personally to our works for repairs either during or after warrantee, after fixing up with our service dept (Customer Support Division). If possible we may repair on same day or your person can stay for a day or two & get it repaired & or calibrated.

(b) After warrantee Services

On expiry of 1yr warrantee if you like to send the equipment (low cost less than 6.0 lakhs) for repairs to our works, you may please observe the following procedure.

Send an e-mail with details mentioning that you agree to pay service charges which includes: Basic service charges per unit / module in the range of Rs: 2500 to Rs : 10,000 depending on the sophistication of the unit calibration charges (if applicable for your equipment) + cost of components + packing charges + Return Freight charges @ actual.

Once our customer support department responds & requests you to despatch the equipment to our works for repairs, you may do so by following the steps given below.

Followed by this you can send the equipment straight away if it is within 5 yrs old. If the equipment is beyond 5 yrs old, then also you can send it for repairs, however only after you receive confirmation from Customer Support Division, that it is repairable & is not an obsolete model. If the design is obsolete then customer support division (CSD) may give you 'buy back' offer to replace with new model or upgrade it with electronic circuit boards & enclosure.

For all installed equipments costing above Rs: 6.0 lakhs which are larger in size & for which field servicing only is recommended, you can obtain a quotation with relevant details by sending an e-mail & avail the services accordingly.

For all field servicing jobs, since we need to depute engineers, it is likely, to take time & also it will cost more which includes Engineer's TA & DA etc., apart from basic service charges + cost of spares etc. Please note that basic service charges will be different for different products depending upon sophistication.

Also in some cases it may not be possible to fix-up the problems in the field itself, in such cases we may advise you to send them to our works.

For all jobs to be serviced in the field, customer is requested to provide adequate details on the nature of problems, to enable our engineer to come prepared with adequate spares.

For any additional information send an e-mail to info@nucleonix.com, Atten: Customer support division.

6.3 EQUIPMENT REPAIRS / SERVICING POLICY (FOR EXPORTS)

Equipments, manufactured & exported are subjected to a well defined quality assurance (QA) plan & Factory acceptance tests (FAT). Nucleonix systems has the following policy to provide maintenance support to overseas customers either directly or through international dealers / distributors.

(a) During & after warranty:

For minor problems, which can be handled by customers, servicing tips have been provided in the user manual / servicing manual.

Also most of the equipments have built-in fault diagnostic features which will indicate to the user nature of problem in the equipment. Based on the visual indication in the instrument Display, user can take corrective action or contact Nucleonix systems by email for help.

Nucleonix systems will guide in localizing the defective part / module or sub-system by interacting with the customer if required. Skype will be used for communication.

During warranty free replacement of sub-system or board (PCB) will be done. However customer has to send defective sub-system back to Nucleonix system with-in 15 days on arranging replacement.

During & after warranty, any Freight charges & customs clearance charges are to be borne by customers, both ways.

If it is a manufacturing defect, then Nucleonix system will bear the replacement cost of sub-system / unit. However any Freight charges & customs clearance charges in their country are to be borne by customer. After warranty, services will be similar to that of services during warranty. However, customer will have to pay for cost of parts replaced, freight charges both ways & customs clearance charges in both the countries. Nucleonix systems plans to introduce audio visuals on web or on CDs to facilitate product demonstration, installation & minor maintenance very soon.

6.4 HOW TO AVAIL CALIBRATION SERVICES (FOR INDIAN CUSTOMERS)

Nucleonix Systems offers radiation calibration services to its customers. Calibration services are provided for Nucleonix Systems manufactured products only, in general, as a company policy.

How to avail calibration services:

It is best advised that each of the Radiation monitors including Area monitors are calibrated once in a year. When you want to send your Radiation monitor / Area monitor / Contamination monitor for calibration to our works. You may send the equipment for calibration, by following the steps given below:

1. Our standard calibration charges per equipment (All types of Radiation monitors including portable survey meters, contamination monitors & Area Gamma Monitors) are Rs: 2500 + Packing + Freight charges. You can email a 'work order' accepting these charges.
2. Email your work order and despatch / send the equipment to our works if it is 5 years old or less including details of mode of transport sent with docket particulars.
3. Also mention in your work order & clearly indicate that you will agree to pay calibration charges & also equipment repair charges additionally if the unit is faulty & requires repairs before one can take it up for calibration.
4. You are requested to ensure good packing to avoid any transportation damages. Especially if there are external detector probes, they are to be packed with sufficient soft foam to ensure no damage in transportation.
5. Use only the specified following mode of transportation system for dispatching on door delivery basis. XPS/GATI cargo / Courier/RPP/Speed Post parcel etc. Send the equipment on freight paid basis. (Equipments sent by other methods such as Rail/Road etc will not be collected). Also you can cover for transit insurance both ways if you wish. Nucleonix system is not responsible for any transportation damages or loss during transportation both ways.
6. Immediately on receipt of the equipment, we will send an acknowledgement & also a proforma bill by email/ post.
7. Based on the proforma bill, once we receive the payment, equipment will be dispatched back by similar mode of transportation as mentioned above.

6.5 HOW TO AVAIL CALIBRATION SERVICES (FOR FOREIGN CUSTOMERS)

Foreign customers can calibrate Nucleonix make Radiation monitors/equipments in their country at any of their accredited Radiation calibration labs. Nucleonix systems will be happy to provide any help and guidance if needed, for calibration. Alternatively if you send the equipment here to India we can also provide calibration services.

Calibration Standards Lab & Facility:
We have two calibration labs.

- i. Low Level Calibration Lab.
- ii. High Dose Rate Calibration lab.

Low Level Calibration Lab: This has a Cs-137, 165 mCi standard. "Gamma Survey Instruments Calibrator" from Amersham.

This calibration service has NIST Traceability standard. Calibration of all portable radiation monitors, survey meters, contamination monitors, Area monitors etc., is carried out in this lab upto 1 R/hr max dose rates.



Gamma Survey instruments calibrator has Cs-137 source 161.5 mCi as on 05 Aug 2002. It is basically a gamma survey instruments calibrator procured from AEA Technologies UK/USA. Has NIST traceability accuracy within +/- 7%

Gamma Survey instruments calibrator has Cs-137 source 161.5 mCi as on 05 Aug 2002. It is basically a gamma survey instruments calibrator procured from AEA Technologies UK/USA. Has NIST traceability accuracy within +/- 7%



CRC-2 camera has Co-60 standard obtained from Bhabha Atomic Research Centre, Mumbai. It is a certified source.

6.5 ANNUAL MAINTENANCE CONTRACT (AMC)

Annual maintenance contract (AMC) services:

For all sophisticated instruments & systems and also for installed monitors & networked systems in a nuclear facility or a Radiological lab or in a Medical cyclotron facility where no. of instruments are networked, it is advised that customer enters into an economical Annual maintenance contract with Nucleonix system.

Detailed AMC proposal can be obtained from our customer support division (CSD), by giving required inputs.

Inputs required by our CSD to send you AMC proposal:

Name, year & date of purchase, Sl. Nos. of equipments, Model No's, No. of equipments for which AMC is required. Additionally no. of calls per annum required for preventive & breakdown maintenance may also be indicated.

Advantage of entering into AMC:

Equipment services offered will be prompt & timely

Nucleonix systems maintain required spares, spare tested PCBs, detectors & other critical components which may become obsolete.

Obsolescence in electronics is quite rapid. If you enter into AMC guaranteed service for the period of AMC will be the responsibility of Nucleonix Systems.

Nucleonix Systems will maintain Engineers at your disposal to attend to AMC calls on time

Without AMC prompt service calls are not guaranteed.

If some critical components become obsolete, then Nucleonix systems may request you to upgrade the product with new model or new electronics which may be expensive if you are not under AMC.

Training on maintenance / servicing:

To a limited extent, we offer training on maintenance / repairs at our works to customers on chargeable basis. Details can be obtained from our customer support division, by customers who may require such services.

CHAPTER –VII

CONTACT US FOR AVAILING SERVICES

Postal/Mailing Address (Phone / Fax / Email)

Nucleonix Systems Pvt Ltd.
Plot No. 162 A&B, Phase II, I.D.A.,
Cherlapally, Hyderabad - 500 051, Telangana, India.
Phone: + 91-7207034546, 68888777
Mobile: 7331104480, 7331104481, 7331104482
Email : info@nucleonix.com

**For any information, Contact by email is always appreciated.
(This will help us to respond to you quickly)**

Marketing Department :

a) Sales / Commercial Information / Field installation and servicing

For any Commercial, Price information, Product information, customer coordination & quotation

of our products customer related commercial services, please contact front office marketing staff through the listed Email Ids or Phone Nos. given below

Whom to Contact:

Business Executives:	Contact Numbers	Contact by E-mail ID
1. R.Maniram (Sr. Business Executive)	Mob:7331104481, + 91-7207034546	info@nucleonix.com
2. Ch.Gayatri (Business Executive)	Mob:7331104481, + 91-7207034546	info@nucleonix.com
3. K.Swapna (Business Executive)	Mob:7331104481, + 91-7207034546	info@nucleonix.com

Note: Our business executives will also connect you to concerned Engineer or General Manager for any technical clarifications if required

b) Factory Services

For **Servicing and Calibration** factory services & follow up on the above jobs including dispatch related/payment related issues of serviced & calibrated items please contact

Ms.K.Sarika
(Executive services)

Mob:7331104482

E-mail: info@nucleonix.com

She will also connect you to concerned engineer or general manager if required, for any clarifications & deficiencies in services

c) Dispatch Related Issues (Production Items)

For dispatch related issues of your ordered equipments, including delays, purchase order related document deficiencies, payment proofs, dispatch docket details and bills etc.,contact

Ms.V.Anusha / Renuka Devi
(Executive Dispatch)

E-mail: info@nucleonix.com

d) Product Technical Information / Clarifications

Whom To Contact:

Contact any front office "Business Executive"- He/She will take your details and connect you to concerned product engineer for any technical clarifications. Best thing is to email your technical queries and obtain the reply, rather than on telephone.

You can also contact General Manager or Director (Tech) if required.

e) Marketing Manager

On business matters for all your marketing services / techno commercial requirements about Nucleonix Products contact:

Bhaskara I.V.
Mob:8019662500
Email: info@nucleonix.com

f) General Manager

Dr.M.S.R.Murthy PhD (Nuclear physics)

Email: info@nucleonix.com

Contact General Manager for all sales / servicing and technical information including customer support related issues, on the delays, gaps & lapses by our staff. Contact G.M. regarding field installations & field servicing jobs schedule etc.

g) H.R -Incharge

Contact her regarding, job vacancies, sending resume for employment, H.R. related issues etc. contact

Ms. Shanthi Sri. P

Mob:7331104480

Email: recruit@nucleonix.com

h) Director -Technical

Mr. J. Dheeraj Reddy

Email: jdreddy@nucleonix.com

Mobile No. +91-7674009005

Contact him for, any Technical Information and clarifications on products, which cannot be answered by General Manager / Customer support executives.

For any technical deficiencies in products, related issues & suggestions on product improvements you may contact by email or telephone. This will help the company to improve the product & serve you better.

Dealer's complaints, on commercials, lapses by our commercial staff, or any other discrepancy, or you like to give any feedback on any Nucleonix staff doing any wrong thing against cleaner / ethical business principles / practices can be complained to any of the directors or managing director.

i) Director - IT

Mr. J. Nishanth Reddy

Email: nishureddy@yahoo.com; info@nucleonix.com

Mobile No. +91-9966691000

For any deficiencies in product software's, related issues, & any suggestions or improvisations in software's can be contact by email or telephone. This will help the company to improve the product & serve you better.

j) Managing Director

Shri. J.Narender Reddy (Managing Director)

Email : jnreddy@nucleonix.com; info@nucleonix.com

Contact Managing Director for, Foreign relations, International Business co-operation, Joint ventures, Exports, Dealership in other countries, Policy matters, Technology tie-ups etc.

k) Dealers Complaints :

Dealers complaints, on commercials, lapses by our commercial staff, or any other discrepancy, or you like to give any feedback on any Nucleonix staff doing any wrong thing against cleaner / ethical business principles / practices can be complained to any of the directors or managing director.

**An innovative company working towards excellence
in the field of Nuclear Instrumentation**



NUCLEONIX SYSTEMS PVT. LTD.

Plot No.162 A & B, Phase-II, IDA, Cherlapally, Hyderabad-500051 INDIA.

Ph : 91-40-27263701, 040-27262146, 68888777 , Fax : 040-27262146

E-mail : info@nucleonix.com website : www.nucleonix.com